



# Datasheet

Backlit LED Panel Light  
P07 Series:TP(a) Fire-proof



### • Product Features

- > Own designed ultra flat casing:32mm
- > 180° degree lens on PCB for Uniform lighting
- > Various of different functions
- > Tri-color is available
- > White frame color:RAL9016
- > 5 years warranty

### • Options

- > Lumen efficiency :
  - Standard : 105 LM/W · Deluxe :140LM/W
- > LED Driver function
  - ON-Off Flicker    · ON-OFF Flicker Free
  - 1-10V dimming    · DALI            · 3H EM

### • Applications

- > Replacement for fluroescent troffer
- > Offices/Schools
- > Hospitals /Retails
- > Corridors /Stairwells

### • Dimension

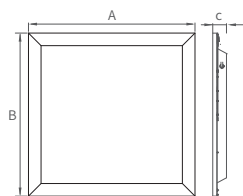

Product Name	A	B	C
600x600	595	595	32
620x620	620	620	32
300x1200	295	1195	32
600x1200	595	1195	32

Unit:mm

### • Product Picture

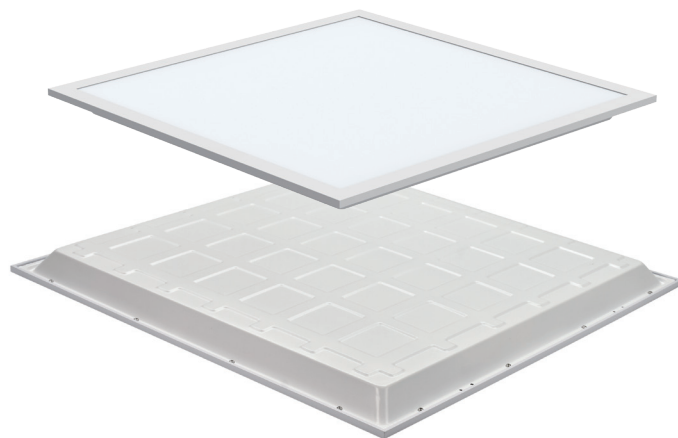

### • Photometry Curve

AVERAGE BEAM ANGLE (50%): 120DEG

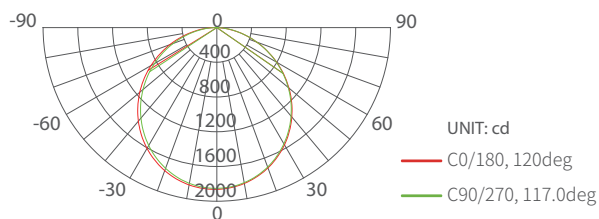

### • Product code policy

**PN XX -XX X XX - X X X X X- XXX**

01    02    03    04    05    06 07 08 09 10    11

01. Product category: PN: LED Panel Light;
02. Product dimension: eg: 22:595\*595mm;
03. Rated power: eg: 30: 30W;
04. Luminous Efficacy: S:Standard 100LM/W;
05. Color Temperature: eg:N1: 4000~4500K;
06. Product version: B: Backlit ;
07. Structural function: V:TP(a) Fire-proof
08. Electrical function:N:ON/OFF
- 09.Power attribute:1:AC200-240V Flicker free power drive
- 10.Power supply manufacturer
- 11.Series No.: 001-499.

• Technical / Electrical Characters (at TA=25°C)

Item	Symbol	Standard : 105 LM/W				Deluxe :140LM/W			
		600X600 mm	300X1200 mm	620X620 mm	600X1200 mm	600X600 mm	300X1200 mm	620X620 mm	600X1200 mm
Rated Power	W	30W	30W	30W	50W	30W	30W	30W	50W
Product Code	/	PN22-30SN1 -BVN1B-001	PN41-30SN1 -BVN1B-001	PN62-30SN1 -BVN1B-001	PN42-50SN1 -BVN1B-001	PN22-30DN1 -BVN1B-001	PN41-30DN1 -BVN1B-001	PN62-30DN1 -BVN1B-001	PN42-50DN1 -BVN1B-001
LED Type/Qty	SMD2835	48	60	48	96	48	60	48	96
Lumen Efficacy	Lm/w	105LM/W	105LM/W	105LM/W	105LM/W	140LM/W	140LM/W	140LM/W	140LM/W
Luminous Flux	LM	3150LM	3150LM	3150LM	5250LM	4200LM	4200LM	4200LM	7000LM
UGR Data	UGR	UGR>19							
Color Index	Ra	Ra>80							
Color Temperature	TC(K)	Single color : WW:3000K, NW:4000K, PW:5000K, CW:6000K Tri-color: 3000/5000K ,mixed:4000K							
Dimming Function	/	ON -OFF / 1-10V Dimming /DALI							
Flicker Free	/	Flicker Free							
LED current	mA	Constant 60mA							
Input Voltage	V	AC200~240V/50Hz							
Working Voltage	V	Constant DC27~42V							
Protection Class	IP	IP20/IP44 Optional							
Temperature	°C	Operation:-15°C~+50°C				Storage:-25°C~+55°C			
Life Span	h	50,000 hours							
Switching Cycle before Failure	/	>100,000 times							
Warranty	/	5 years							

• ErP Technical Specification

Item	Symbol	Specification / Data
Power factor	PF	>0.9
Efficiency in	%	>88%
Energy efficiency Class	/	Standard:A+ , Deluxe:A++
Standard deviation of color matching	/	<5
Starting Time	S	<0.1S
Warm-up time to 60%	S	<0.5S
Rated nominal Lifetime	/	>50,000 hours
Driver MTBF	/	500,000H.MIL-HDBK-217F(25°C)
Lumen Maintenance at e.o.l.	%	>70%
LED Device Lifetime	/	L80/B10@50,000 hours



• Link Drawing

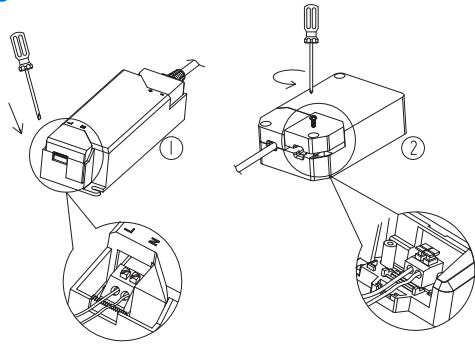

1.Insert the AC line “L”、“N” terminal,use screws to fix protective cover

Standard Edition

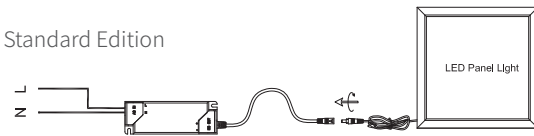

1-10V Dimmer

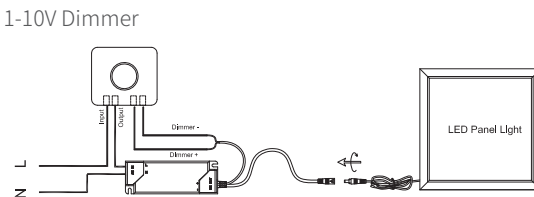

• Installation Instructions

Schematic diagram for recessed installation

1.Connect the power input wire,then fixed power supply

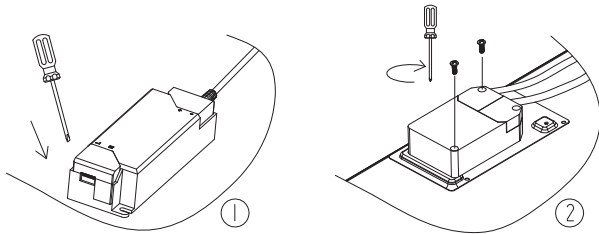

2.Connect the power line,then put LED panel on the ceiling screens.

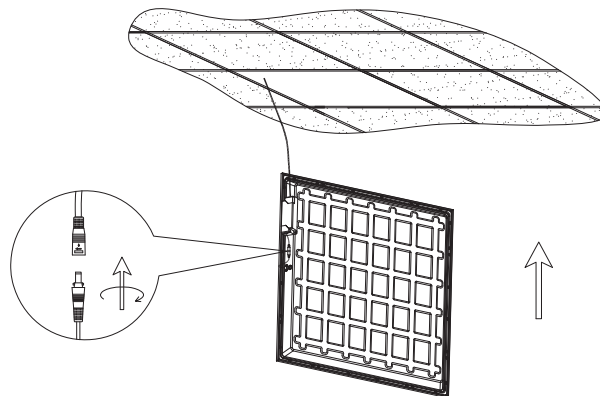

3.Check LED panel is mounted properly and securely.

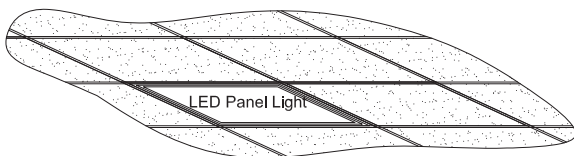

• Package

Product Type	Rated Power	Inner Box	Outer Carton	Qty/Carton	Unit N.W	G.W/Carton
600 x 600mm	30W	600 x 40x 625mm	615 x 430x 650mm	10 pcs	1.85Kg	23.75Kg
620 x 620mm	30W	640 x 40x 650mm	655 x 445x 670mm	10 pcs	1.95kg	24.50Kg
300 x 1200mm	30W	1265 x 40x 310mm	1280 x 230x 330mm	5 pcs	1.85Kg	12.00Kg
600 x 1200mm	50W	1265 x 40x 610mm	1280 x 230x 630mm	5pcs	3.55Kg	24.00Kg

**!** CAUTION

- ※ In case of electric shock, please make sure the power is off before installation.
- ※ The lamp should be installed and operated by a qualified electrician or technician in accordance with relevant local codes.
- ※ Do not use sharp tools near or on the surface of the lamp.
- ※ Unpack and examine the product carefully. Report any damage and save all packing materials if any portion of the product was damaged during transportation.